



SHENZHEN AGLARE LIGHTING CO., LTD.

Tel: +86-755-88868631

FAX: +86-755-88863251

E-mail: Aglare@aglare.cn

Website: <http://www.aglare.cn>

Add: Factory A, Supply and Marketing Cooperative Park Guanlan Avenue, Guanlan Town Bao'an District, Shenzhen City, Guangdong, China

Specification for Approval

Customer: _____

Product: YJ-D63PAR38-12X1W

Part No.: _____

Ref. No: _____

Date: 2010-06-14

Made by Shenzhen Aglare Lighting Co. Ltd

Production Dept	Q.C. Dept	Engineering Dept	Marketing Dept
Wen Liu	Fang Yang	Jiang Yang	Fang Wang

Approved by

Engineering Dept	Production Dept	Q.C. Dept	Manager



SHENZHEN AGLARE LIGHTING CO., LTD.

Tel: +86-755-88868631

FAX: +86-755-88863251

E-mail: Aglare@aglare.cn

Website: <http://www.aglare.cn>

Add: Factory A, Supply and Marketing Cooperative Park Guanlan Avenue, Guanlan Town Bao'an District, Shenzhen City, Guangdong, China

1.Features:

1. High-power LEDs
2. Input voltage: 110 to 220V AC
3. Light sources: 12 pieces high-power LED
4. Power dissipation: 12W
5. Luminous intensity:
 - a) Red:715-845LM
 - b) Green:715-845 M
 - c) Blue:182-234 M
 - d) Yellow:715-780 LM
 - e) White:910-1300 LM
 - f) Warm White:845-1170LM
6. Dimensions: 118 x 138mm
7. Net weight: 689.2g
8. Shake-resistant
9. Green product
10. Colors available: white, yellow, red, green, blue and warm white
11. Viewing angle: 15~80° (selectable)

Picture:



2.Application Case:





SHENZHEN AGLARE LIGHTING CO., LTD.

Tel: +86-755-88868631 FAX: +86-755-88863251 E-mail: Aglare@aglare.cn Website: <http://www.aglare.cn>
Add: Factory A, Supply and Marketing Cooperative Park Guanlan Avenue, Guanlan Town Bao'an District, Shenzhen City, Guangdong, China



3.Package Dimensions (mm):

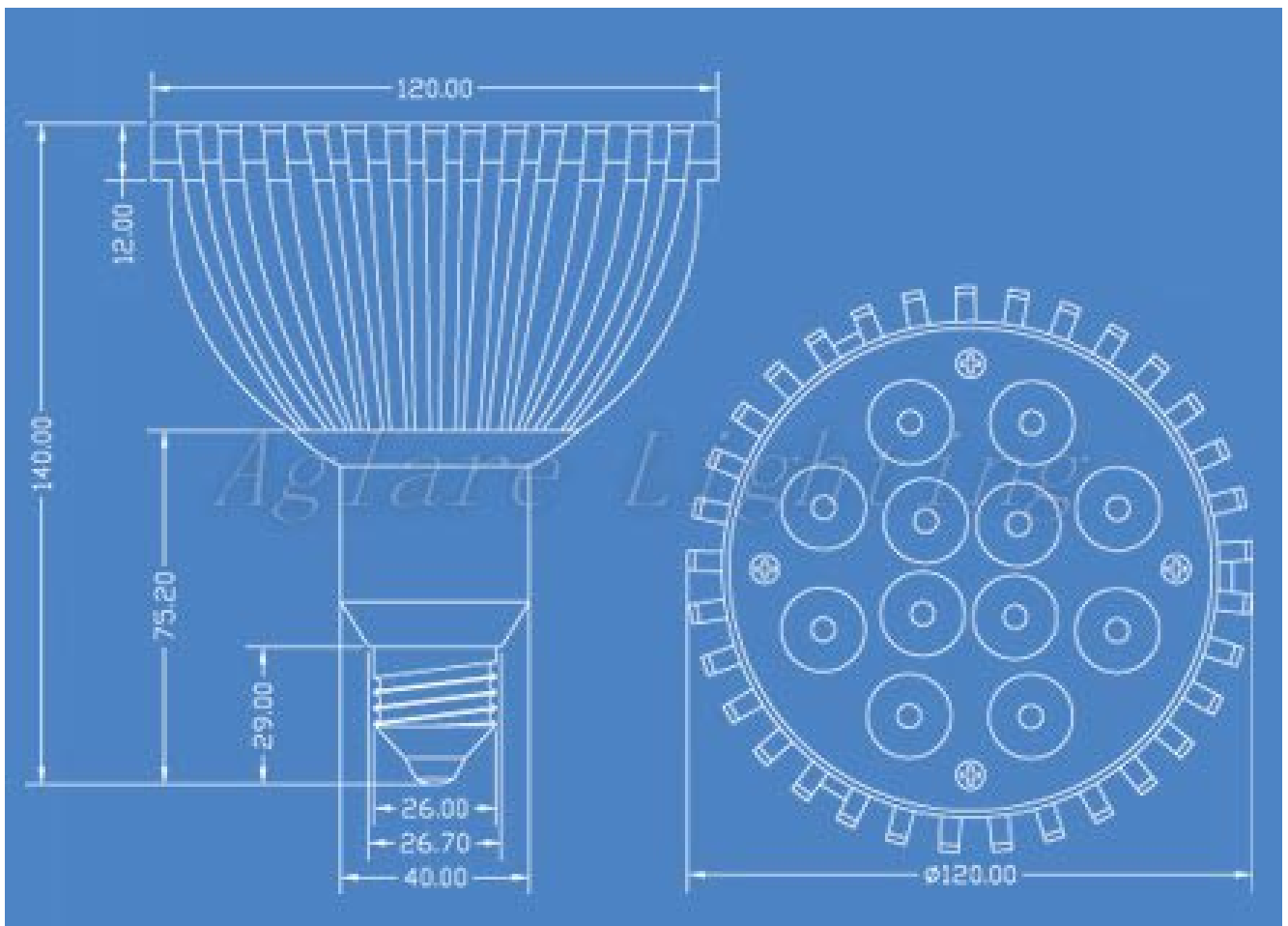

4.Absolute Maximum Rating at TA=25°C:



SHENZHEN AGLARE LIGHTING CO., LTD.

Tel: +86-755-88868631

FAX: +86-755-88863251

E-mail: Aglare@aglare.cn

Website: <http://www.aglare.cn>

Add: Factory A, Supply and Marketing Cooperative Park Guanlan Avenue, Guanlan Town Bao'an District, Shenzhen City, Guangdong, China

Part Number	Emitting Color	Input Voltage	Wattage	Waterpro of Degree	LED Quantity	Luminous Intensity(Lm)		Net Weight (g)
						MIN	MAX	
YJ-D63PAR38-12X1R	Red	AC90-24 0V	12W	/	12pcs	715	845	283g
YJ-D63PAR38-12X1G	Green			/		715	845	
YJ-D63PAR38-12X1B	Blue			/		182	234	
YJ-D63PAR38-12X1Y	Yellow			/		715	780	
YJ-D63PAR38-12X1W	Pure White			/		910	1300	
YJ-D63PAR38-12X1WW	Warm White			/		845	1170	

5. Characteristic:

Electro-Optical characteristics (White)		(Ta=25°C)			Unit	
Parameter	Test Condition	Symbol	Value			
			Min	Typ	Max	
Color temperature	If=320mA		5000		6500	K
Forward Voltage	If=320mA		3.0		3.8	V
Luminous Intensity	If=320mA		910		1300	LM
Useful life	If=320mA		30000		50000	H

6. Lumen Decrease

Operating time (hours)	Lumen decrease [%]
1000	8
5000	15
10000	20

7. Package Information:



SHENZHEN AGLARE LIGHTING CO., LTD.

Tel: +86-755-88868631

FAX: +86-755-88863251

E-mail: Aglare@aglare.cn

Website: <http://www.aglare.cn>

Add: Factory A, Supply and Marketing Cooperative Park Guanlan Avenue, Guanlan Town Bao'an District, Shenzhen City, Guangdong, China

Net (g)	Gross (kg)	Box Size (cm)	Q'ty/BOX (PCS)	CTN1 Size (cm)	Q'ty/CTN1 (PCS)
283	9.49	12.5*12.5*14.5	1	63*38*28.5	30

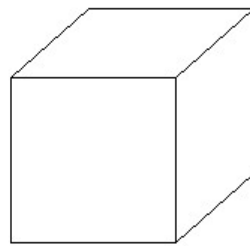
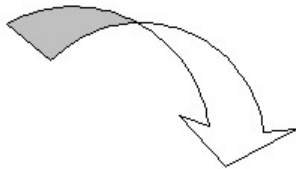
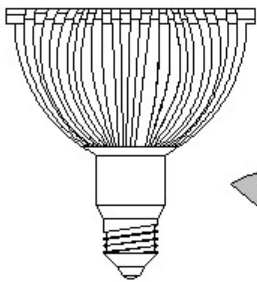

BOX

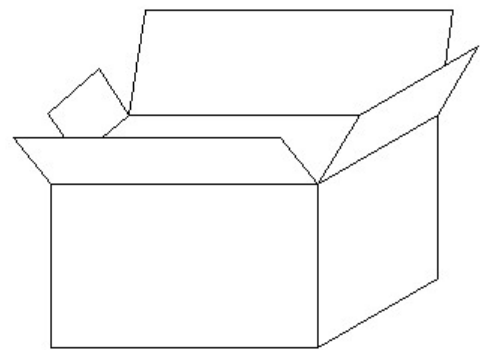
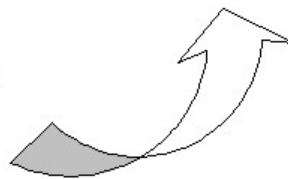

Carton 1

8. After-sales service:

All products are guaranteed to use in one year. Under the right and normal using condition, quality warranty is based on correct conservation, assemblage, and maintenance. As incorrect usage, and disobeying product operation, it's not guaranteed. To the problem within promised time, "Aglare" will solve it by repair, substitute accessories or replacement for your option. Upon exceeding the promised time, there will be material and maintenance fees to be paid by cu

TEL: +86-755-88868631 FAX: +86-755-88863251 E-mail: service@aglare.cn