



SHENZHEN AGLARE LIGHTING CO., LTD.

Tel: +86-755-88868631 FAX: +86-755-88863251 E-mail: Aglare@aglare.cn Website: <http://www.aglare.cn>
Add: Factory A, Supply and Marketing Cooperative Park Guanlan Avenue, Guanlan Town Bao'an District, Shenzhen City, Guangdong, China

Specification for Approval

Customer: _____

Product: YJ-DL180R12X1W-B

Part No.: _____

Ref. No: _____

Date: 2010-06-30

Made by Shenzhen Aglare Lighting Co. Ltd

Production Dept	Q.C. Dept	Engineering Dept	Marketing Dept
Wen Liu	Fang Yang	Jiang Yang	Fang Wang

Approved by

Engineering Dept	Production Dept	Q.C. Dept	Manager



SHENZHEN AGLARE LIGHTING CO., LTD.

Tel: +86-755-88868631

FAX: +86-755-88863251

E-mail: Aglare@aglare.cn

Website: <http://www.aglare.cn>

Add: Factory A, Supply and Marketing Cooperative Park Guanlan Avenue, Guanlan Town Bao'an District, Shenzhen City, Guangdong, China

1.Features:

1. Ceiling spotlights
2. LED quantity: 12 pieces
3. LED type: 1w high power led
4. Operating condition: 350mA
5. Input voltage: AC 85-260V
6. Total power consumption: 12W
7. Colors available: white, warm white, red, blue, green and yellow.
8. Lifespan: 50,000 hours
9. Net weight: 420g
10. Maximum size: 180*180*79 mm
11. Viewing angle: 95° (selectable)

Picture:



2.Application Case:





SHENZHEN AGLARE LIGHTING CO., LTD.

Tel: +86-755-88868631

FAX: +86-755-88863251

E-mail: Aglare@aglare.cn

Website: <http://www.aglare.cn>

Add: Factory A, Supply and Marketing Cooperative Park Guanlan Avenue, Guanlan Town Bao'an District, Shenzhen City, Guangdong, China



3.Package Dimensions (mm):

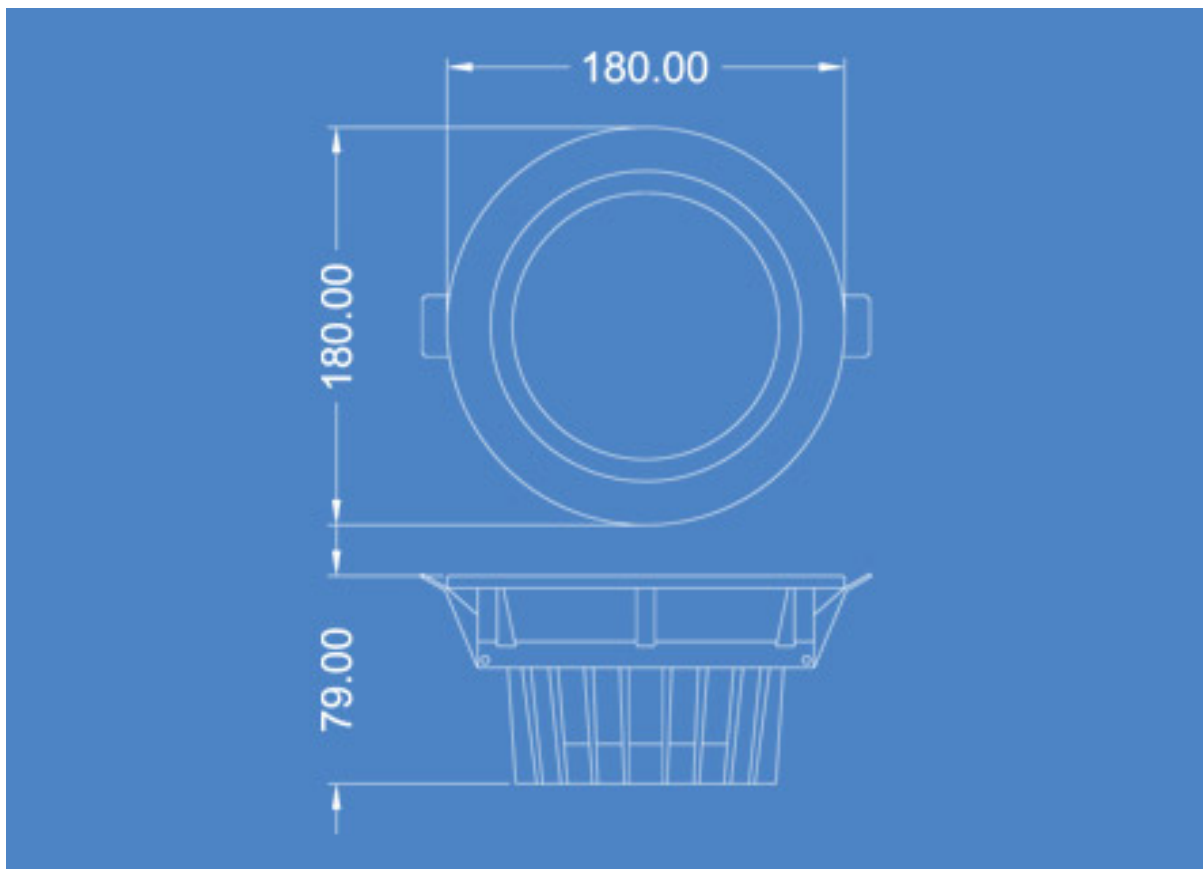



SHENZHEN AGLARE LIGHTING CO., LTD.

Tel: +86-755-88868631

FAX: +86-755-88863251

E-mail: Aglare@aglare.cn

Website: <http://www.aglare.cn>

Add: Factory A, Supply and Marketing Cooperative Park Guanlan Avenue, Guanlan Town Bao'an District, Shenzhen City, Guangdong, China

4. Absolute Maximum Rating at TA=25°C:

Part Number	Emitting Color	Input Voltage	Wattage	Waterproof Degree	LED Quantity	Luminous Intensity(Lm)		Net Weight (g)
						MIN	MAX	
YJ-DL180R12X1R-B	Red	AC90-240V	12W	/	12pcs	528	624	420g
YJ-DL180R12X1G-B	Green		12W	/	12pcs	528	624	420g
YJ-DL180R12X1B-B	Blue		12W	/	12pcs	134	172	420g
YJ-DL180R12X1Y-B	Yellow		12W	/	12pcs	528	576	420g
YJ-DL180R12X1W-B	Pure White		12W	/	12pcs	672	960	420g
YJ-DL180R12X1WW-B	Warm White		12W	/	12pcs	624	864	420g

5. Characteristic:

Electro-Optical characteristics (Pure White) (Ta=25°C)						
Parameter	Test Condition	Symbol	Value			Unit
			Min	Typ	Max	
Color temperature	If=350mA		5000		6500	K
Forward voltage	If=350mA	VF	3.2		3.8	V
Power consumption	If=350mA	P	11	12	13	W
Luminous intensity	If=350mA	Iv	672	800	960	LM
Reverse current	VF=5V	IR	--	--	5	UA
Useful life	IF=350mA		30000		50000	H

6. Lumen Decrease

Operating time (hours)	Lumen decrease [%]
1000	8
5000	15
10000	20



SHENZHEN AGLARE LIGHTING CO., LTD.

Tel: +86-755-88868631

FAX: +86-755-88863251

E-mail: Aglare@aglare.cn

Website: <http://www.aglare.cn>

Add: Factory A, Supply and Marketing Cooperative Park Guanlan Avenue, Guanlan Town Bao'an District, Shenzhen City, Guangdong, China

8. Package Information:

Net (g)	Gross (kg)	Carton1 Size (CM)	Carton2 Size (CM)	Q'ty/Carton 1
420	14.5	21.0*21.0*8.5	84.5*84.5*17.5	32

9. After-sales service

All products are guaranteed to use in one year. Under the right and normal using condition, quality warranty is based on correct conservation, assemblage, and maintenance. As incorrect usage, and disobeying product operation, it's not guaranteed. To the problem within promised time, "Aglare" will solve it by repair, substitute accessories or replacement for your option. Upon exceeding the promised time, there will be material and maintenance fees to be paid by c

TEL: +86-755-88868631 FAX: +86-755-88863251 E-mail: service@aglare.cn