



SHENZHEN AGLARE LIGHTING CO., LTD.

Tel: +86-755-88868631

FAX: +86-755-88863251

E-mail: Aglare@aglare.cn

Website: <http://www.aglare.cn>

Add: Factory A, Supply and Marketing Cooperative Park Guanlan Avenue, Guanlan Town Bao'an District, Shenzhen City, Guangdong, China

Specification for Approval

Customer: _____

Product: YJ-D27PAR38A-12X1R

Part No.: _____

Ref. No: _____

Date: 2010-06-14

Made by Shenzhen Aglare Lighting Co. Ltd

Production Dept	Q.C. Dept	Engineering Dept	Marketing Dept
Wen Liu	Fang Yang	Jiang Yang	Fang Wang

Approved by

Engineering Dept	Production Dept	Q.C. Dept	Manager



SHENZHEN AGLARE LIGHTING CO., LTD.

Tel: +86-755-88868631

FAX: +86-755-88863251

E-mail: Aglare@aglare.cn

Website: <http://www.aglare.cn>

Add: Factory A, Supply and Marketing Cooperative Park Guanlan Avenue, Guanlan Town Bao'an District, Shenzhen City, Guangdong, China

1.Features:

1. Input voltage: 110 to 220V AC
2. Light sources: 12 pieces high-power LED
3. Power dissipation: 12 x 1W
4. Luminous intensity:
 - a) Red:480-720LM
 - b) Green:720-1080LM
 - c) Blue 100-245LM
 - d) Yellow:480-720LM
 - e) White:840-1080LM
 - f) Warm White:650-865LM
5. Shake-resistant
6. Colors: white, yellow, red, green, blue and warm white
7. Dimensions: (D) 118 x (H) 138mm
8. Net weight: 654g
9. Viewing angle:15~80° (selectable)

Picture:



2.Application Case:





SHENZHEN AGLARE LIGHTING CO., LTD.

Tel: +86-755-88868631 FAX: +86-755-88863251 E-mail: Aglare@aglare.cn Website: <http://www.aglare.cn>
Add: Factory A, Supply and Marketing Cooperative Park Guanlan Avenue, Guanlan Town Bao'an District, Shenzhen City, Guangdong, China



3.Package Dimensions (mm):

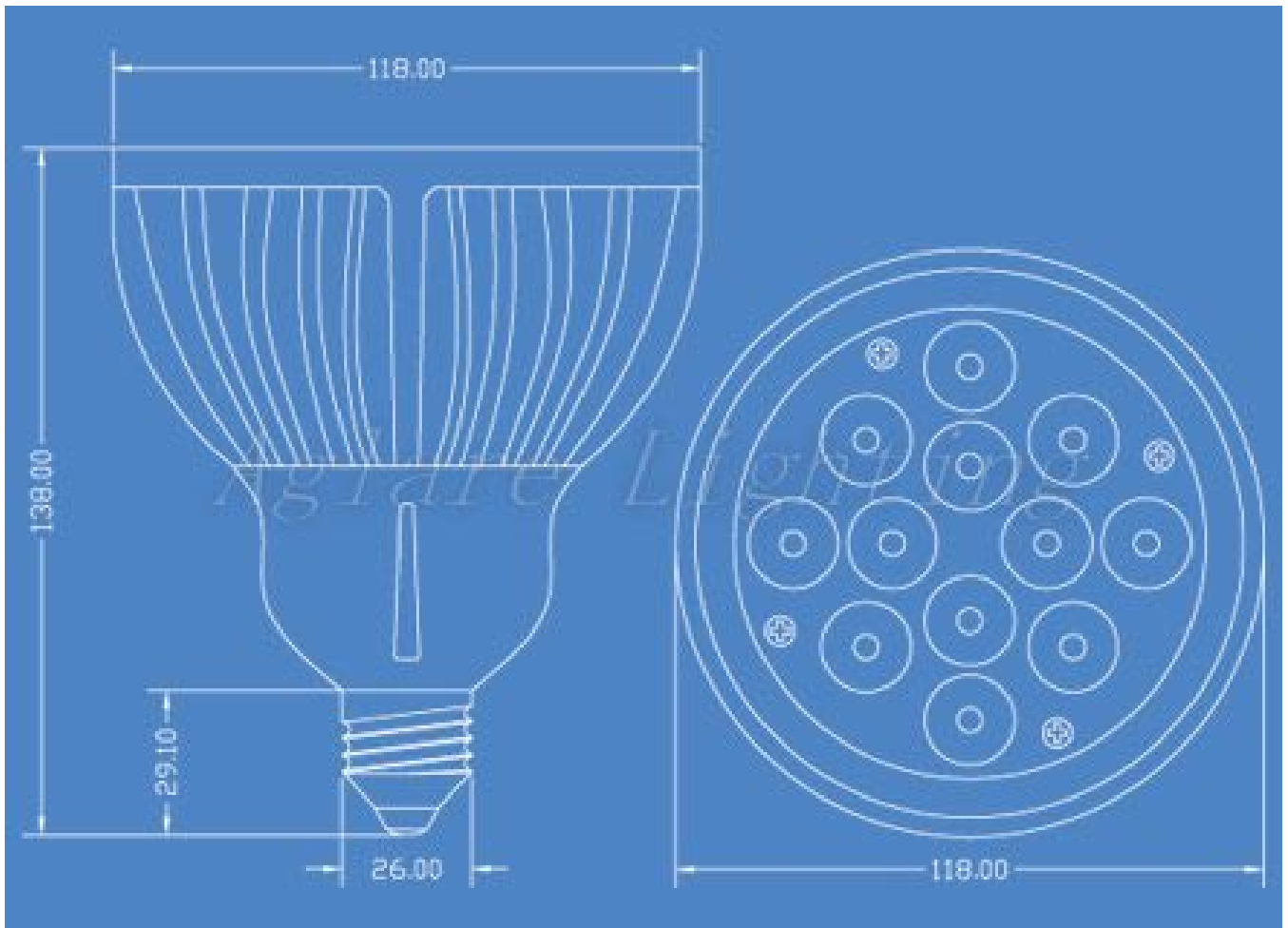



SHENZHEN AGLARE LIGHTING CO., LTD.

Tel: +86-755-88868631 FAX: +86-755-88863251 E-mail: Aglare@aglare.cn Website: <http://www.aglare.cn>
Add: Factory A, Supply and Marketing Cooperative Park Guanlan Avenue, Guanlan Town Bao'an District, Shenzhen City, Guangdong, China

4. Absolute Maximum Rating at TA=25°C:

Part Number	Emitting Color	Input Voltage	Wattage	Waterpro of Degree	LED Quantity	Luminous Intensity(Lm)		Net Weight (g)
						MIN	MAX	
YJ-D27PAR38A-12*1R	Red	AC 110V-AC220V	12W	/	12pcs	480	720	654
YJ-D27PAR38A-12*1G	Green			/		720	1080	
YJ-D27PAR38A-12*1B	Blue			/		100	245	
YJ-D27PAR38A-12*1Y	Yellow			/		480	720	
YJ-D27PAR38A-12*1W	Pure White			/		840	1080	
YJ-D27PAR38A-12*1WW	Warm White			/		650	865	

5. Characteristic:

Electro-Optical characteristics (Red)						(Ta=25°C)	
Parameter	Test Condition	Symbol	Value			Unit	
			Min	Typ	Max		
Wavelength	If=350mA		620		635	nm	
Forward Voltage	If=350mA		3.0		3.8	V	
Useful life	IF=350mA		30000		50000	H	

6. Lumen Decrease

Operating time (hours)	Lumen decrease [%]
1000	8
5000	15
10000	20



SHENZHEN AGLARE LIGHTING CO., LTD.

Tel: +86-755-88868631

FAX: +86-755-88863251

E-mail: Aglare@aglare.cn

Website: <http://www.aglare.cn>

Add: Factory A, Supply and Marketing Cooperative Park Guanlan Avenue, Guanlan Town Bao'an District, Shenzhen City, Guangdong, China

7. Package Information:

Net (g)	Gross (kg)	Box Size (cm)	Q'ty/BOX (PCS)	CTN1 Size (cm)	Q'ty/CTN1 (PCS)
654	11.5	12.5*12.5*14.5	1	65*35*30	16

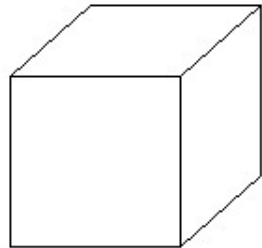
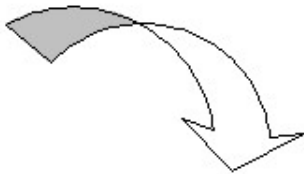
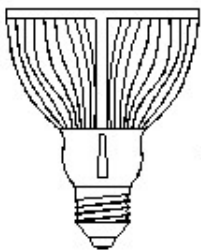

BOX

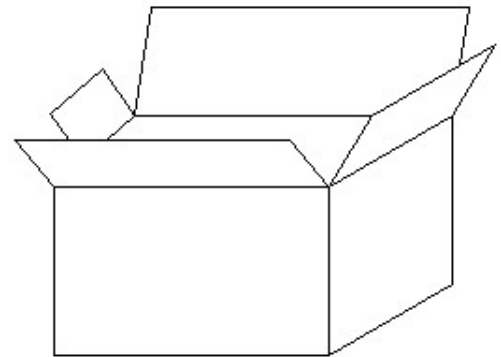
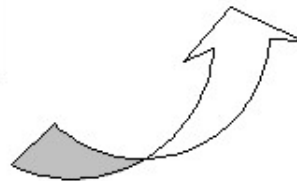

Carton 1

8. After-sales service:

All products are guaranteed to use in one year. Under the right and normal using condition, quality warranty is based on correct conservation, assemblage, and maintenance. As incorrect usage, and disobeying product operation, it's not guaranteed. To the problem within promised time, "Aglare" will solve it by repair, substitute accessories or replacement for your option. Upon exceeding the promised time, there will be material and maintenance fees to be paid by cu