



SHENZHEN AGLARE LIGHTING CO., LTD.

Tel: +86-755-88868631

FAX: +86-755-88863251

E-mail: Aglare@aglare.cn

Website: <http://www.aglare.cn>

Add: Factory A, Supply and Marketing Cooperative Park Guanlan Avenue, Guanlan Town Bao'an District, Shenzhen City, Guangdong, China

Specification for Approval

Customer: _____

Product: YJ-D22MR11-1R

Part No.: _____

Ref. No: _____

Date: _____

Made by Shenzhen Aglare Lighting Co. Ltd

Production Dept	Q.C. Dept	Engineering Dept	Marketing Dept
Wen Liu	Fang Yang	Jiang Yang	Fang Wang

Approved by

Engineering Dept	Production Dept	Q.C. Dept	Manager



SHENZHEN AGLARE LIGHTING CO., LTD.

Tel: +86-755-88868631

FAX: +86-755-88863251

E-mail: Aglare@aglare.cn

Website: <http://www.aglare.cn>

Add: Factory A, Supply and Marketing Cooperative Park Guanlan Avenue, Guanlan Town Bao'an District, Shenzhen City, Guangdong, China

1.Features:

1. Light source: high-power LED
2. With aluminum alloy heat sink structure
3. Input voltage: 12V AC
4. Power: 1W
5. Beam angle: 25 to 35 degree
6. Luminous intensity:
 - a) Red: 55 to 65lm
 - b) Green: 55 to 65lm
 - c) Blue: 14 to 18lm
7. Working temperature: -20 to +40 degree
8. Colors: red, green, blue, white and warm white
9. Energy saving light with long lifespan
10. Net weight: 27g

Picture:



3.Package Dimensions (mm):

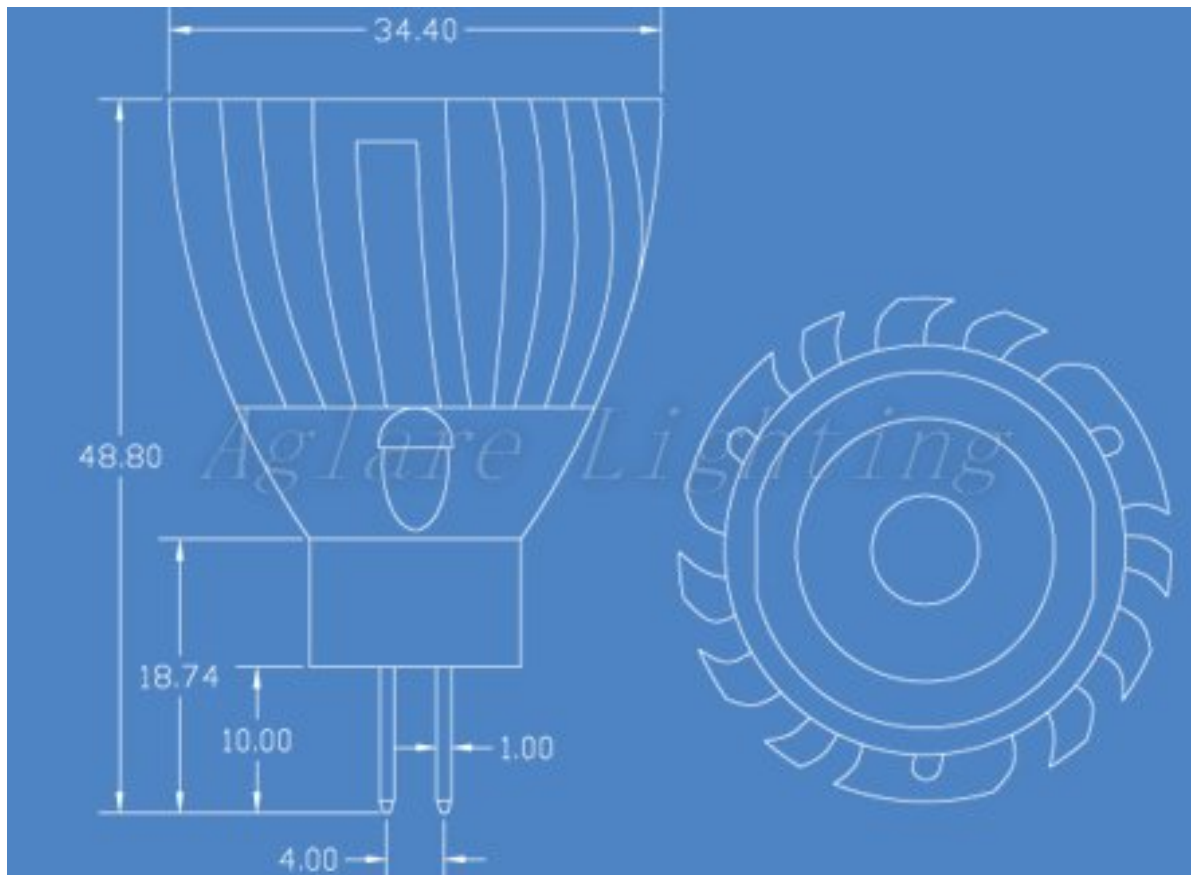



SHENZHEN AGLARE LIGHTING CO., LTD.

Tel: +86-755-88868631

FAX: +86-755-88863251

E-mail: Aglare@aglare.cn

Website: <http://www.aglare.cn>

Add: Factory A, Supply and Marketing Cooperative Park Guanlan Avenue, Guanlan Town Bao'an District, Shenzhen City, Guangdong, China

4. Absolute Maximum Rating at TA=25°C:

Part Number	Emitting Color	Input Voltage	Wattage	Waterpro of Degree	LED Quantity	Luminous Intensity(Lm)		Net Weight
						MIN	MAX	
YJ-D22MR11-1R	Red	AC12V	1W	/	1pcs	55	65	27g
YJ-D22MR11-1G	Green		1W	/	1pcs	55	65	27g
YJ-D22MR11-1B	Blue		1W	/	1pcs	14	18	27g
YJ-D22MR11-1Y	Yellow		1W	/	1pcs	55	60	27g
YJ-D22MR11-1W	Pure White		1W	/	1pcs	70	100	27g
YJ-D22MR11-1WW	Warm White		1W	/	1pcs	65	90	27g

5 Characteristic:

Electro-Optical characteristics (Red)

(Ta=25°C)

Parameter	Test Condition	Symbol	Value			Unit
			Min	Typ	Max	
Wavelength	If=350mA		620		635	nm
Forward voltage	If=350mA		3.2		3.8	V
Luminous intensity	If=350mA		55		65	LM
Viewing angle at 50% IV	If=180mA		25	30	35	Deg
Useful life	IF=350mA		30000		50000	H

6. Lumen Decrease

Operating time (hours)	Lumen decrease [%]
1000	8
5000	15
10000	20



SHENZHEN AGLARE LIGHTING CO., LTD.

Tel: +86-755-88868631

FAX: +86-755-88863251

E-mail: Aglare@aglare.cn

Website: <http://www.aglare.cn>

Add: Factory A, Supply and Marketing Cooperative Park Guanlan Avenue, Guanlan Town Bao'an District, Shenzhen City, Guangdong, China

7. Application Case:

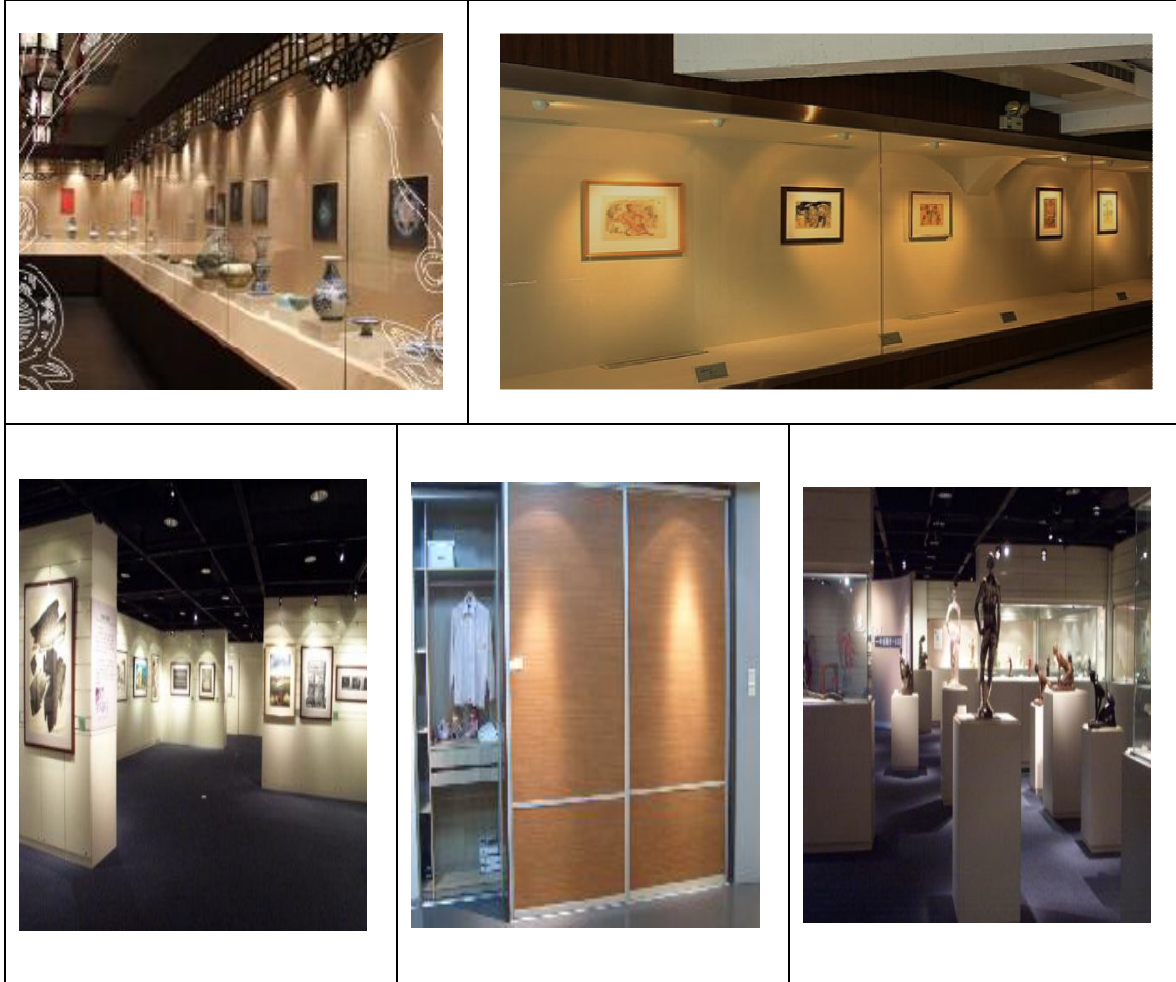

8. Caution:

1. Applicable Voltage: AC12V
2. Operating temperature: $-30^{\circ}\text{C} \sim +50^{\circ}\text{C}$.
3. The power voltage is permitted in $+10\% \sim -10\%$ fluctuating. If it's beyond the said scope, it would influence lifespan, even unlighted or burnt out.
4. Make sure connecting wire is connected and sealed well to avoid defending Electricity Leakage.
5. Make sure waterproof protection, and no defending Water leakage before connecting to extra power supply.
6. Before maintenance, make sure the power cut off. After assembling right, it can be connected power to use.
7. No breaking to any stipulation of fireproofing. Please ask Profesional to install.



SHENZHEN AGLARE LIGHTING CO., LTD.

Tel: +86-755-88868631

FAX: +86-755-88863251

E-mail: Aglare@aglare.cn

Website: <http://www.aglare.cn>

Add: Factory A, Supply and Marketing Cooperative Park Guanlan Avenue, Guanlan Town Bao'an District, Shenzhen City, Guangdong, China

9. Package Information:

Net (g)	Gross (kg)	Box Size (cm)	CTN1 Size (cm)	Q'ty/CTN1 (pcs)	CTN2 Size (cm)	Q'ty/CTN2 (pcs)
27	7.4	5*5*6.8	28.5*28.5*15	50	61*30*35	200

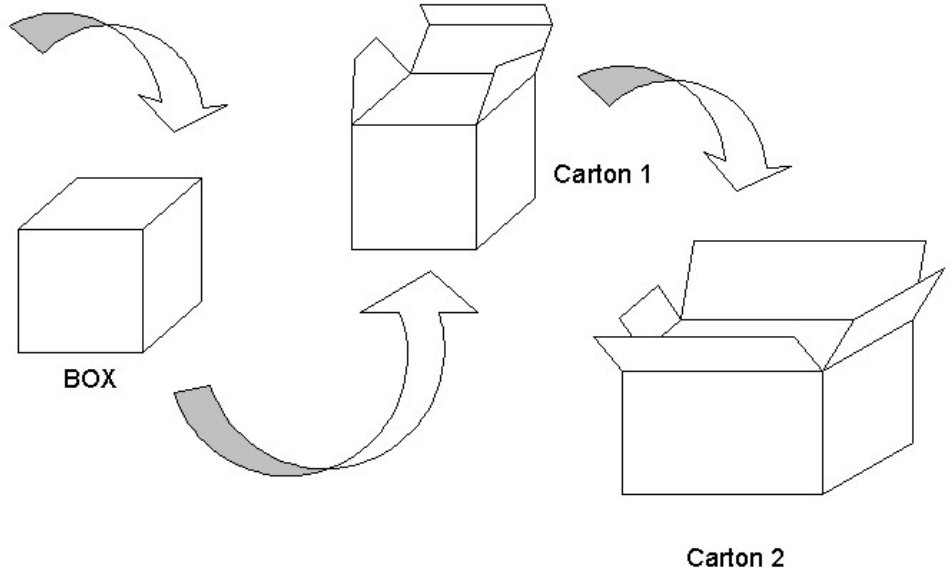
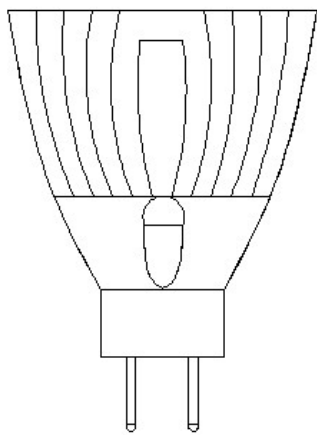

10. After-sales service:

All products are guaranteed to use in one year. Under the right and normal using condition, quality warranty is based on correct conservation, assemblage, and maintenance. As incorrect usage, and disobeying product operation, it's not guaranteed. To the problem within promised time, "Aglare" will solve it by repair, substitute accessories or replacement for your option. Upon exceeding the promised time, there will be material and maintenance fees to be paid by customers.