



YJ-LS5050RGB30 LED Flexible Strip Specification

1. Features:

- × Low power consumption, vivid lighting color
- × Defending Electricity Leakage
- × Easy to install, maintenance free
- × Big viewing angle, long lifespan
- × Green product, compliant with ROHS and CE.

2. Application:

- × Decoration for indoor illumination
- × Slim characteristic for Lighting sign etc.

Picture:



3. Package Dimensions (mm):

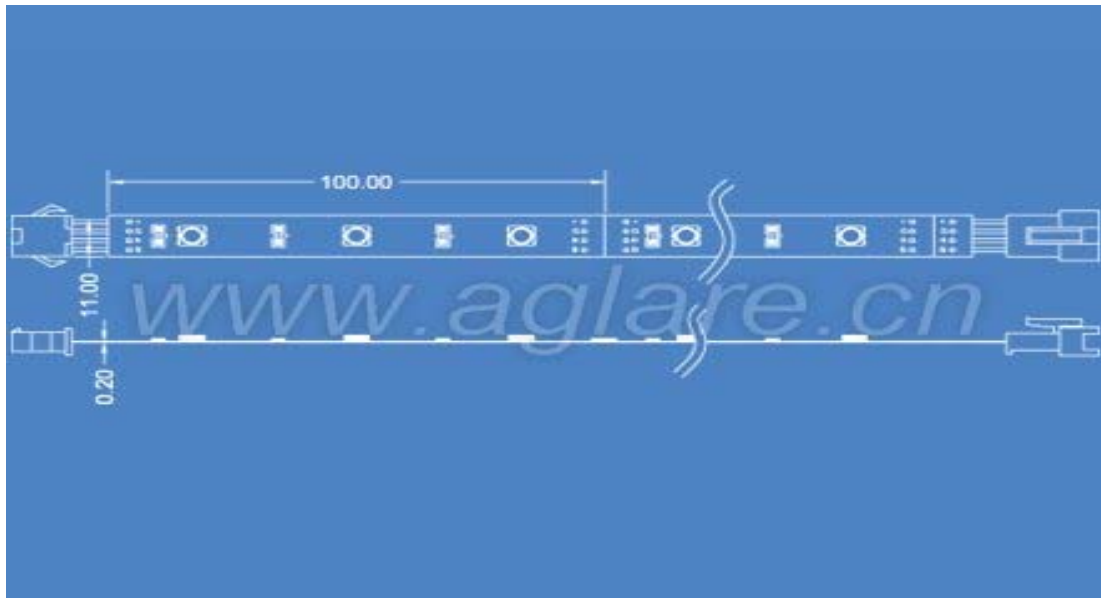

- 1). All dimensions are in millimeters
- 2). Tolerance is 0.5 mm unless otherwise noted
- 3). One strip connected by 3 Units and every 3 SMDs can be cut of
- 4). 60 SMDs divisible in 3 Double-steps
- 5). Voltage supply: 12 VDC

Circuits:

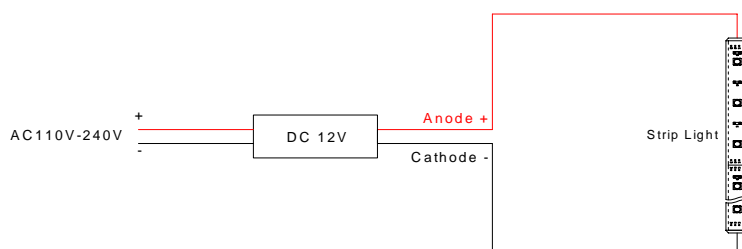



4. YJ-LS5050RGB30 Characteristic:

LIGHT EMITTING DIODE LAMPS			
Absolute maximum ratings		(Ta=25°C)	
	Symbol	Value	Unit
Forward current	If	60	mA
Reverse voltage	Vf	5	V
Power dissipation	Pd	172	mW
Operating temperature range	Top	-25~+80	°C
Storage temperature range	Top	-30~+80	°C
Peak pulsing current (1/8 duty f=1KHz)	If	125	mA

5. Absolute Maximum Rating at TA=25°C:

Part Number	Emitting Color	Input Voltage	Wattage	Water proof Degree	LED Quantity	Colour Temperature(k)	Wavelength (nm)	Luminous Intensity (Lm/M)		Continuous Connect (m)
								MIN	MAX	
YJ-LS5050R30	Red	DC12V	6.48W/M	/	30pcs	/	619-635	240	360	10-15
YJ-LS5050G30	Green		6.48W/M	/	30pcs	/	512-528	360	480	10-15
YJ-LS5050B30	Blue		6.48W/M	/	30pcs	/	463-475	60	120	10-15
YJ-LS5050Y30	Yellow		6.48W/M	/	30pcs	/	584-595	240	360	10-15
YJ-LS5050W30	Pure White		6.48W/M	/	30pcs	5500-6500	/	420	540	10-15
YJ-LS5050WW30	Warm White		6.48W/M	/	30pcs	2700-3900	/	360	450	10-15
YJ-LS5050RGB30	R G B		6.48W/M	/	30pcs	/	/	150	180	10-15



6. Installation:

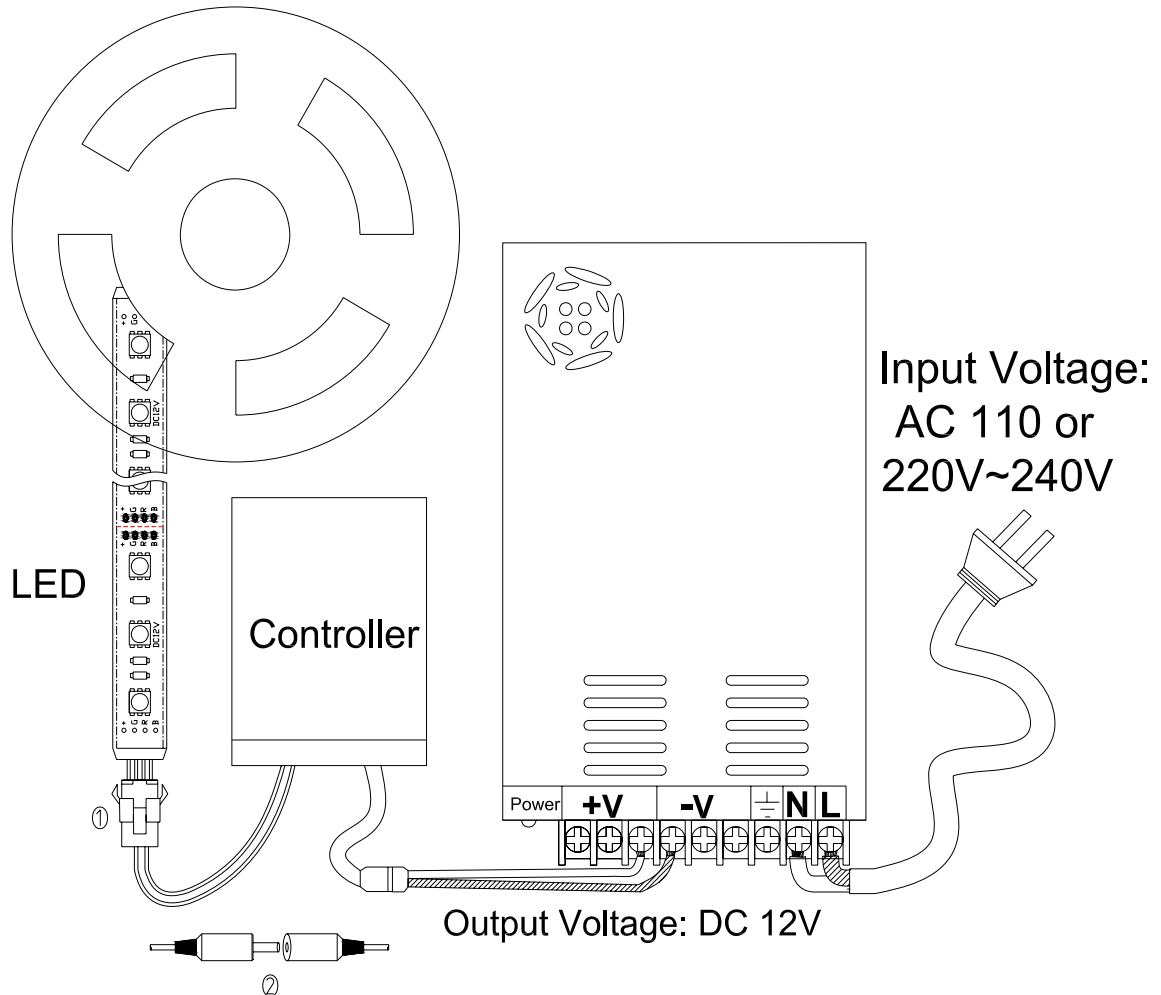

7. Power Adapter Application Information:

Length	From 0 to 1.25m	From 1.25 to 2.5m	From 2.5 to 5m
Suggested Power Adapter	6W/12V/0.5A	12W/12V/1A	24W/12V/2A
Power Adapter Item Number			
Voltage	12V	12V	12V
Current	Up to 400mA	Up to 800mA	Up to 1600mA
Section	From 0 to 40	From 40 to 80	From 80 to 160



8. Packing:

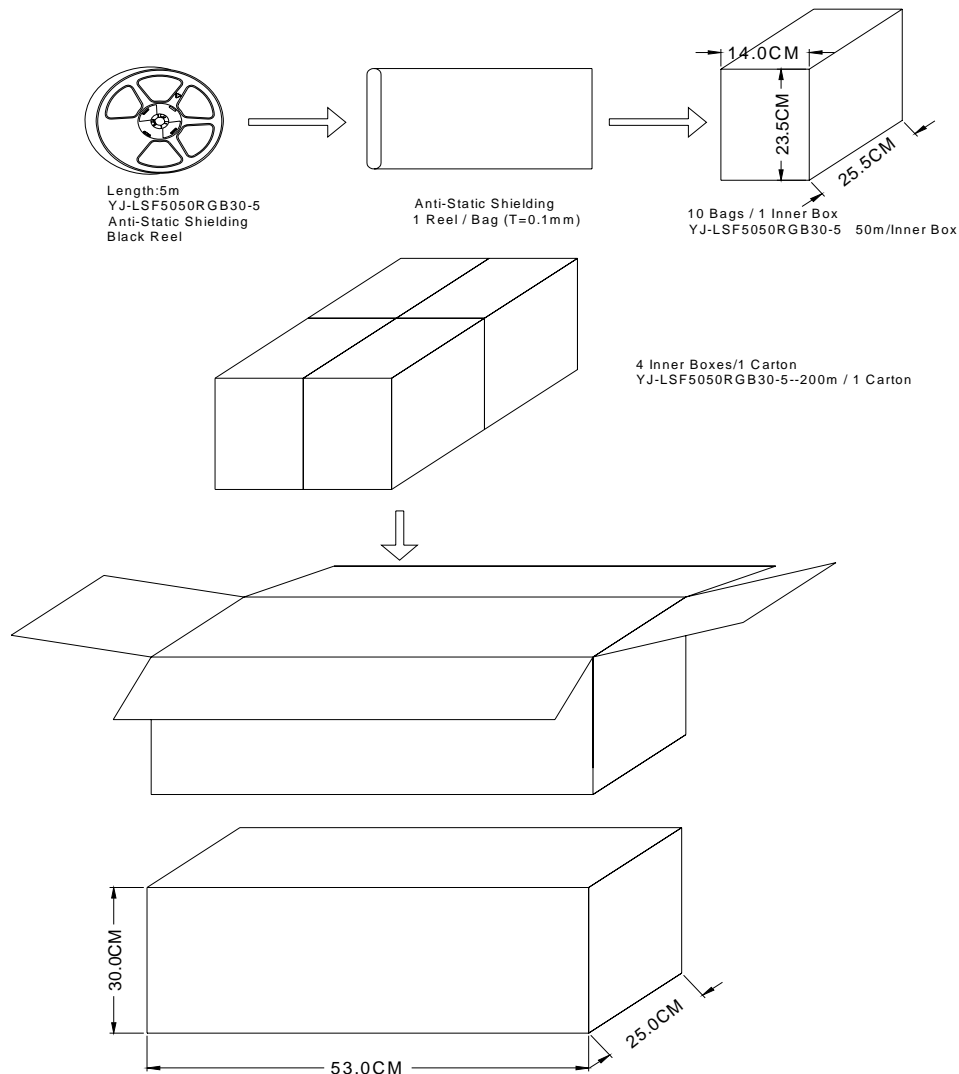

9. After-sales service:

All products are guaranteed to use in one year. Under the right and normal using condition, quality warranty is based on correct conservation, assemblage, and maintenance. As incorrect usage, and disobeying product operation, it's not guaranteed. To the problem within promised time, "Aglare" will solve it by repair, substitute accessories or replacement for your option. Upon exceeding the promised time, there will be material and maintenance fees to be paid by customers.

TEL: +86-755-88868631 FAX: +86-755-88863251 E-mail: service@aglare.cn