



SHENZHEN AGLARE LIGHTING CO., LTD.

Tel: +86-755-88868631

FAX: +86-755-88863251

E-mail: Aglare@aglare.cn

Website: <http://www.aglare.cn>

Add: Factory A, Supply and Marketing Cooperative Park Guanlan Avenue, Guanlan Town Bao'an District, Shenzhen City, Guangdong, China

Specification for Approval

Customer: _____

Product: YJ-D8HR16-3X1R

Part No.: _____

Ref. No: _____

Date: _____

Made by Shenzhen Aglare Lighting Co. Ltd

Production Dept	Q.C. Dept	Engineering Dept	Marketing Dept
Wen Liu	Fang Yang	Jiang Yang	Fang Wang

Approved by

Engineering Dept	Production Dept	Q.C. Dept	Manager



SHENZHEN AGLARE LIGHTING CO., LTD.

Tel: +86-755-88868631

FAX: +86-755-88863251

E-mail: Aglare@aglare.cn

Website: <http://www.aglare.cn>

Add: Factory A, Supply and Marketing Cooperative Park Guanlan Avenue, Guanlan Town Bao'an District, Shenzhen City, Guangdong, China

1.Features:

1. Type: 1W high-power LED
2. LED quantity: 3 pieces
3. Base: E27
4. Rated power: 3W
5. Input voltage: 110 to 220V AC
6. High brightness
7. Viewing angle: 20;
8. Luminous intensity:
 - a) Red: 120 to 175lm
 - b) Green: 190 to 270lm
 - c) Blue: 30 to 40lm
9. Lifespan: 50,000 hours
10. Colors: red, yellow, green, blue, white and purple
11. Alloy aluminum and multi holes body makes it radiate thermal efficiently
12. Projection angle adjustable to lighting effects
13. Dimensions: (D) 48.42 x (H) 57mm
14. Net weight: 57g

Picture:



3.Package Dimensions (mm):

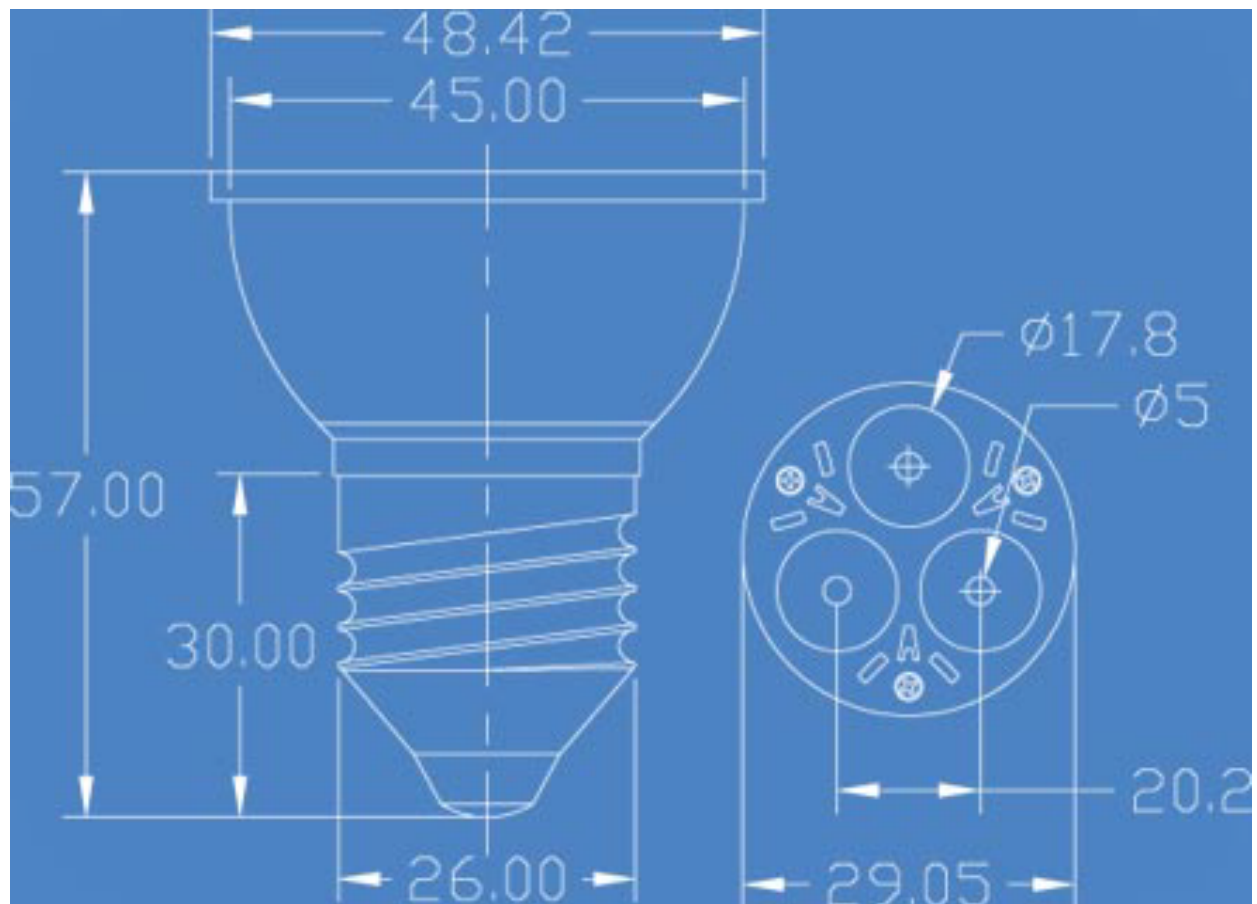



SHENZHEN AGLARE LIGHTING CO., LTD.

Tel: +86-755-88868631

FAX: +86-755-88863251

E-mail: Aglare@aglare.cn

Website: <http://www.aglare.cn>

Add: Factory A, Supply and Marketing Cooperative Park Guanlan Avenue, Guanlan Town Bao'an District, Shenzhen City, Guangdong, China

4. Absolute Maximum Rating at TA=25°C:

Part Number	Emitting Color	Input Voltage	Wattage	Waterpro of Degree	LED Quantity	Luminous Intensity(Lm)		Net Weight
						MIN	MAX	
YJ-D8HR16-3*1R	Red	AC 110~220V	3W	/	3pcs	130	180	57g
YJ-D8HR16-3*1G	Green					200	280	
YJ-D8HR16-3*1B	Blue					35	45	
YJ-D8HR16-3*1Y	Yellow					130	180	
YJ-D8HR16-3*1W	Pure White					200	280	
YJ-D8HR16-3*1W W	Warm White					160	220	

5 Characteristic:

Electro-Optical characteristics (Red)

(Ta=25°C)

Parameter	Test Condition	Symbol	Value			Unit
			Min	Typ	Max	
Wavelength	If=350mA		620		635	nm
Luminous intensity	If=350mA		130		180	LM
Forward Voltage	If=350mA		3.0		3.8	V
Useful life	If=350mA		30000		50000	H

6. Lumen Decrease

Operating time (hours)	Lumen decrease [%]
1000	8
5000	15
10000	20



SHENZHEN AGLARE LIGHTING CO., LTD.

Tel: +86-755-88868631

FAX: +86-755-88863251

E-mail: Aglare@aglare.cn

Website: <http://www.aglare.cn>

Add: Factory A, Supply and Marketing Cooperative Park Guanlan Avenue, Guanlan Town Bao'an District, Shenzhen City, Guangdong, China

7. Application Case:

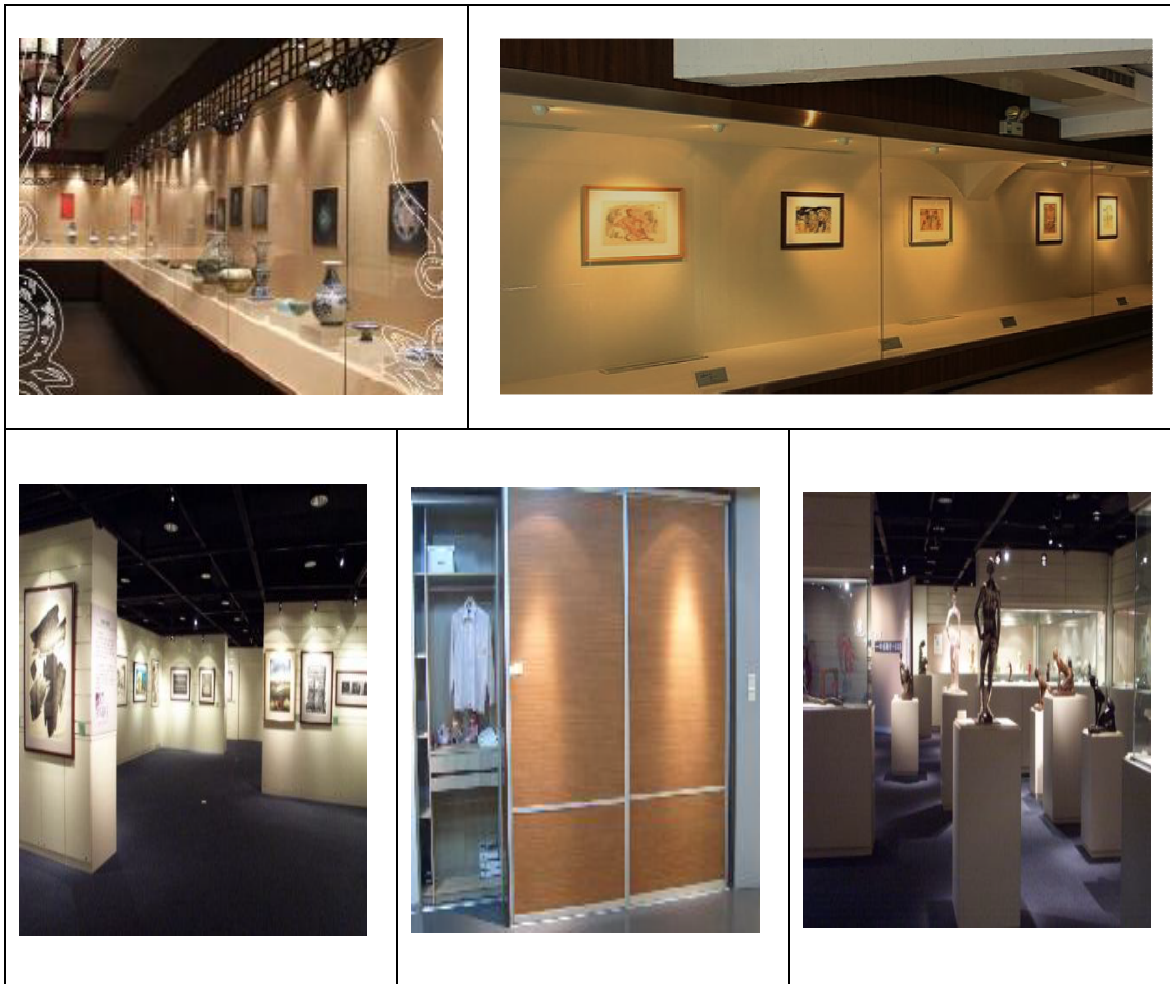

8. Caution:

1. Applicable Voltage: AC110~220V
2. Operating temperature: -30℃ ~ +50℃.
3. The power voltage is permitted in +10%~-10% fluctuating. If it's beyond the said scope, it would influence lifespan, even unlighted or burnt out.
4. Make sure connecting wire is connected and sealed well to avoid defending Electricity Leakage.
5. Make sure waterproof protection, and no defending Water leakage before connecting to extra power supply.
6. Before maintenance, make sure the power cut off. After assembling right, it can be connected power to use.
7. No breaking to any stipulation of fireproofing. Please ask Professional to install.



SHENZHEN AGLARE LIGHTING CO., LTD.

Tel: +86-755-88868631

FAX: +86-755-88863251

E-mail: Aglare@aglare.cn

Website: <http://www.aglare.cn>

Add: Factory A, Supply and Marketing Cooperative Park Guanlan Avenue, Guanlan Town Bao'an District, Shenzhen City, Guangdong, China

9. Package Information:

Net (g)	Gross (kg)	Box Size (cm)	CTN1 Size (cm)	Q'ty/CTN1 (pcs)	CTN2 Size (cm)	Q'ty/CTN2 (pcs)
57	13	5*5*6.8	28.5*28.5*15	50	61*30*35	200

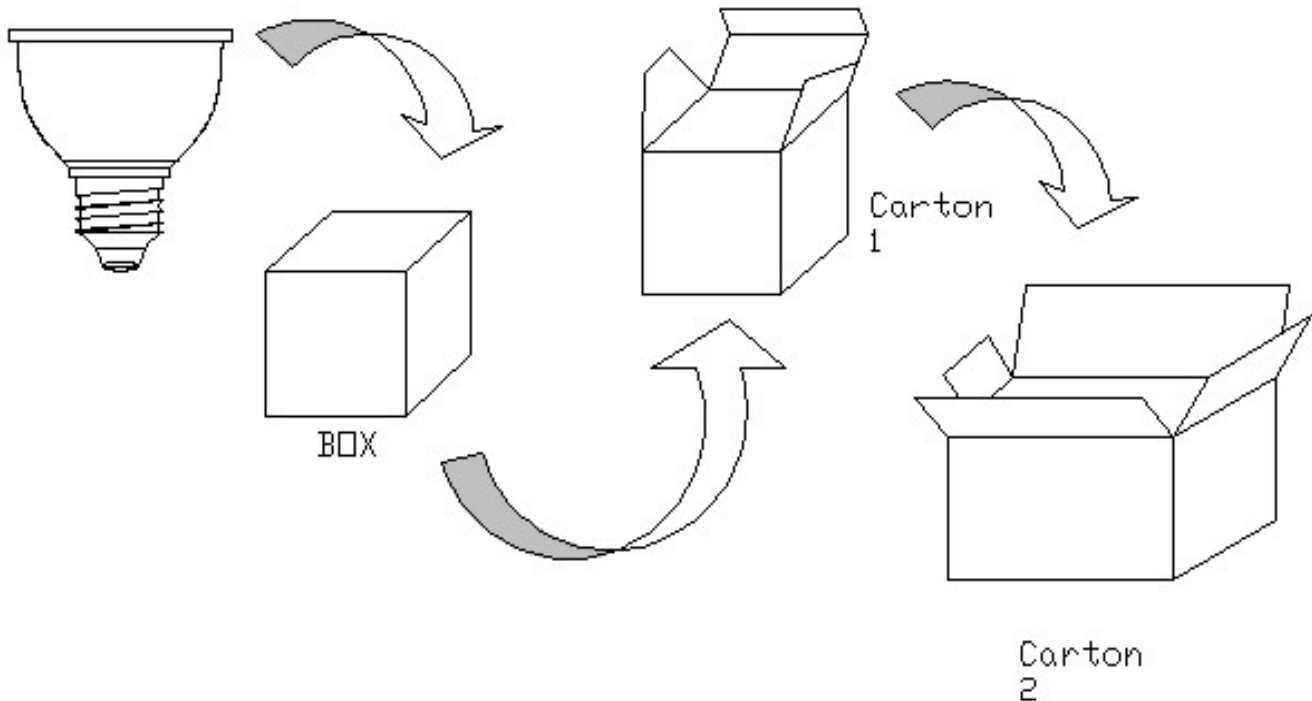

10. After-sales service:

All products are guaranteed to use in one year. Under the right and normal using condition, quality warranty is based on correct conservation, assemblage, and maintenance. As incorrect usage, and disobeying product operation, it's not guaranteed. To the problem within promised time, "Aglare" will solve it by repair, substitute accessories or replacement for your option. Upon exceeding the promised time, there will be material and maintenance fees to be paid by customers.