



SHENZHEN AGLARE LIGHTING CO., LTD.

Tel: +86-755-88868631 FAX: +86-755-88863251 E-mail: Aglare@aglare.cn Website: <http://www.aglare.cn>
Add: Factory A, Supply and Marketing Cooperative Park Guanlan Avenue, Guanlan Town Bao'an District, Shenzhen City, Guangdong, China

Specification for Approval

Customer: _____

Product: YJ-D59AR80-5X1W

Part No.: _____

Ref. No: _____

Date: 2010-07-01

Made by Shenzhen Aglare Lighting Co. Ltd

Production Dept	Q.C. Dept	Engineering Dept	Marketing Dept
Wen Liu	Fang Yang	Jiang Yang	Fang Wang

Approved by

Engineering Dept	Production Dept	Q.C. Dept	Manager



SHENZHEN AGLARE LIGHTING CO., LTD.

Tel: +86-755-88868631

FAX: +86-755-88863251

E-mail: Aglare@aglare.cn

Website: <http://www.aglare.cn>

Add: Factory A, Supply and Marketing Cooperative Park Guanlan Avenue, Guanlan Town Bao'an District, Shenzhen City, Guangdong, China

1.Features:

- × Low power consumption, vivid lighting color
- ×Defending Electricity Leakage
- ×Easy to install, maintenance free
- ×Big viewing angle, long lifespan
- ×Green product, compliant with ROHS and CE.

2.Application:

- ×Decoration for indoor illumination
- ×Slim characteristic for Lighting sign etc.

Picture:



3.Package Dimensions (mm):

4.Absolute Maximum Rating at TA=25°C:

Part Number	Emitting Color	Input Voltage	Wattage	Waterpro of Degree	LED Quantity	Luminous Intensity(Lm)		Net Weight
						MIN	MAX	
YJ-D59AR80-5*1R	Red	AC/DC12V	5*1W	/	5pcs	275	317	80g
YJ-D59AR80-5*1G	Green					275	3317	
YJ-D59AR80-5*1B	Blue					70	90	
YJ-D59AR80-5*1Y	Yellow					266	300	
YJ-D59AR80-5*1W	Pure White					350	500	
YJ-D59AR80-5*1W W	Warm White					333	450	



SHENZHEN AGLARE LIGHTING CO., LTD.

Tel: +86-755-88868631

FAX: +86-755-88863251

E-mail: Aglare@aglare.cn

Website: <http://www.aglare.cn>

Add: Factory A, Supply and Marketing Cooperative Park Guanlan Avenue, Guanlan Town Bao'an District, Shenzhen City, Guangdong, China

5. Characteristic:

Electro-Optical characteristics (White)

(Ta=25°C)

Parameter	Test Condition	Symbol	Value			Unit
			Min	Typ	Max	
Color temperature	If=320mA		5000		6500	K
Forward Voltage	If=320mA		3.0		3.8	V
Luminous intensity	If=320mA		350		500	LM
Useful life	IF=320mA		30000		50000	H

6.Lumen Decrease

Operating time (hours)	Lumen decrease [%]
1000	8
5000	15
10000	20



SHENZHEN AGLARE LIGHTING CO., LTD.

Tel: +86-755-88868631

FAX: +86-755-88863251

E-mail: Aglare@aglare.cn

Website: <http://www.aglare.cn>

Add: Factory A, Supply and Marketing Cooperative Park Guanlan Avenue, Guanlan Town Bao'an District, Shenzhen City, Guangdong, China

7.Application Case:

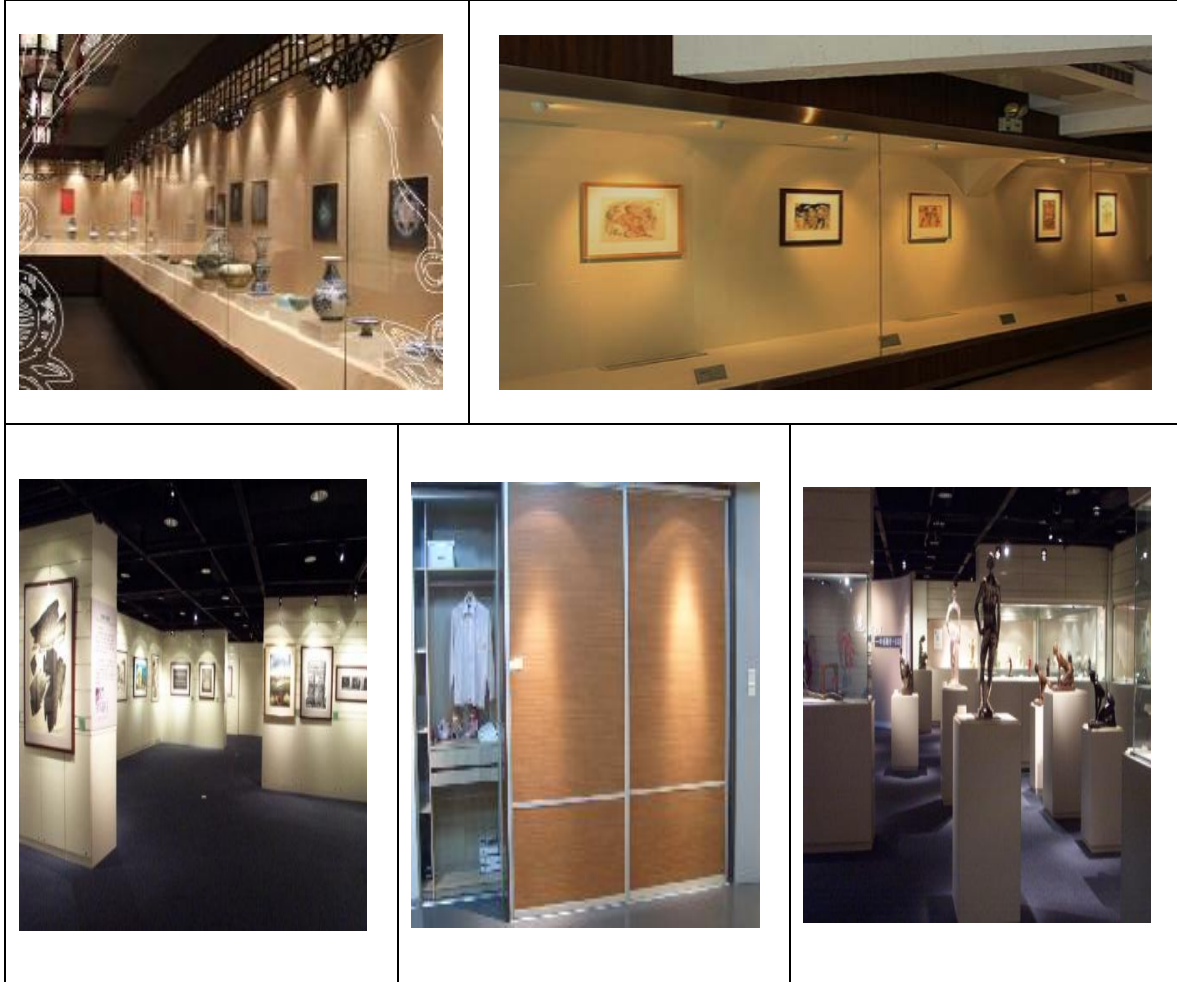

8.Caution:

1. Applicable Voltage: AC/DC12V
2. Operating temperature: $-30^{\circ}\text{C} \sim +50^{\circ}\text{C}$.
3. The power voltage is permitted in $+10\% \sim -10\%$ fluctuating. If it's beyond the said scope, it would influence lifespan, even unlighted or burnt out.
4. Make sure connecting wire is connected and sealed well to avoid defending Electricity Leakage.
5. Make sure waterproof protection, and no defending Water leakage before connecting to extra power supply.
6. Before maintenance, make sure the power cut off. After assembling right, it can be connected power to use.
7. No breaking to any stipulation of fireproofing. Please ask Professional to install.



SHENZHEN AGLARE LIGHTING CO., LTD.

Tel: +86-755-88868631

FAX: +86-755-88863251

E-mail: Aglare@aglare.cn

Website: <http://www.aglare.cn>

Add: Factory A, Supply and Marketing Cooperative Park Guanlan Avenue, Guanlan Town Bao'an District, Shenzhen City, Guangdong, China

9. Package Information:

Net (g)	Gross (kg)	Box Size (cm)	CTN2 Size (cm)	Q'ty/CTN2 (pcs)
80	9	8.5*8.5*6.0	43*43*24.5	100

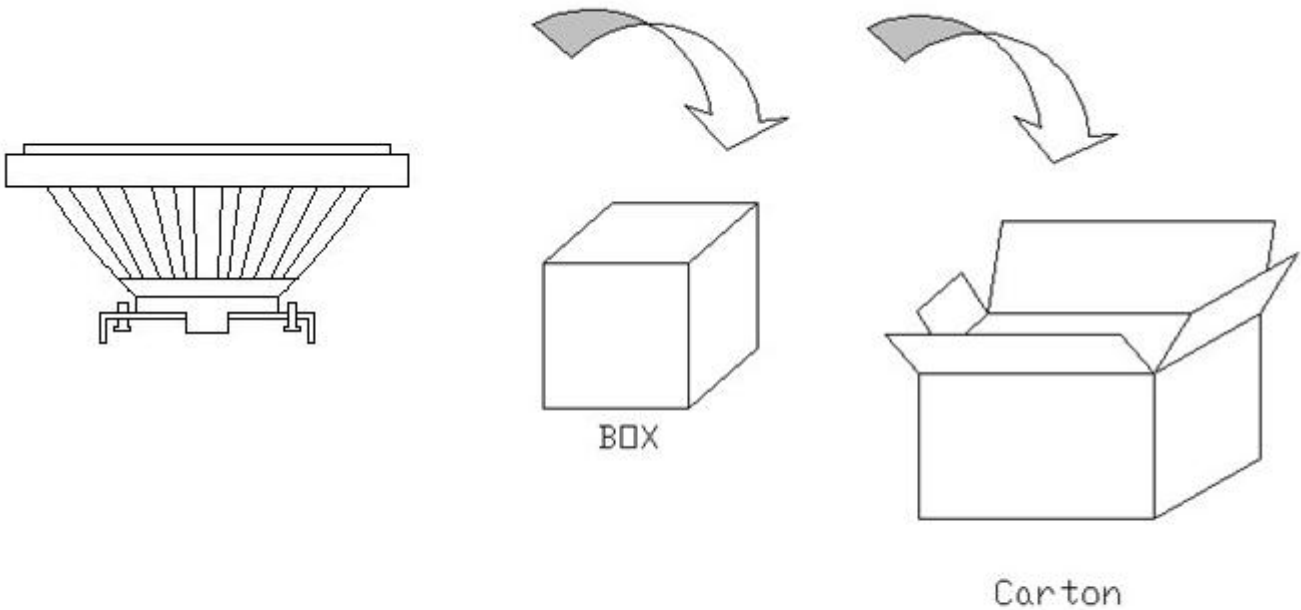

10. After-sales service:

All products are guaranteed to use in one year. Under the right and normal using condition, quality warranty is based on correct conservation, assemblage, and maintenance. As incorrect usage, and disobeying product operation, it's not guaranteed. To the problem within promised time, "Aglare" will solve it by repair, substitute accessories or replacement for your option. Upon exceeding the promised time, there will be material and maintenance fees to be paid by customers.



SHENZHEN AGLARE LIGHTING CO., LTD.

Tel: +86-755-88868631 FAX: +86-755-88863251 E-mail: Aglare@aglare.cn Website: <http://www.aglare.cn>
Add: Factory A, Supply and Marketing Cooperative Park Guanlan Avenue, Guanlan Town Bao'an District, Shenzhen City, Guangdong, China

TEL: +86-755-88868631 FAX: +86-755-88863251 E-mail: service@aglare.cn