



SHENZHEN AGLARE LIGHTING CO., LTD.

Tel: +86-755-88868631

FAX: +86-755-88863251

E-mail: Aglare@aglare.cn

Website: <http://www.aglare.cn>

Add: Factory A, Supply and Marketing Cooperative Park Guanlan Avenue, Guanlan Town Bao'an District, Shenzhen City, Guangdong, China

Specification for Approval

Customer: _____

Product: YJ-D60PAR20-5X1W

Part No.: _____

Ref. No: _____

Date: 2010-06-14

Made by Shenzhen Aglare Lighting Co. Ltd

Production Dept	Q.C. Dept	Engineering Dept	Marketing Dept
Wen Liu	Fang Yang	Jiang Yang	Fang Wang

Approved by

Engineering Dept	Production Dept	Q.C. Dept	Manager



SHENZHEN AGLARE LIGHTING CO., LTD.

Tel: +86-755-88868631

FAX: +86-755-88863251

E-mail: Aglare@aglare.cn

Website: <http://www.aglare.cn>

Add: Factory A, Supply and Marketing Cooperative Park Guanlan Avenue, Guanlan Town Bao'an District, Shenzhen City, Guangdong, China

1.Features:

1. Type: high-power LED
2. LED quantity: 5 pieces
3. Input voltage: 110 to 220V AC
4. Power dissipation: 5 x 1W
6. Available in various colors
7. Protection grade: IP55
8. Aluminum profiles body material and gear appearance for efficient thermal radiation
9. Netlike lens cover used for diverging light
10. Water and dust-resistant
11. Dimensions: (D) 60.2 x (H) 92.8mm
12. Net weight: 72g
13. Ideal Energy Saving Lights for landscape, architecture light, cabaret application, villa, hotel, restaurant, meeting room, exhibition hall, show case, clothespress

Picture:



2.Application Case:





SHENZHEN AGLARE LIGHTING CO., LTD.

Tel: +86-755-88868631 FAX: +86-755-88863251 E-mail: Aglare@aglare.cn Website: <http://www.aglare.cn>
Add: Factory A, Supply and Marketing Cooperative Park Guanlan Avenue, Guanlan Town Bao'an District, Shenzhen City, Guangdong, China



3.Package Dimensions (mm):

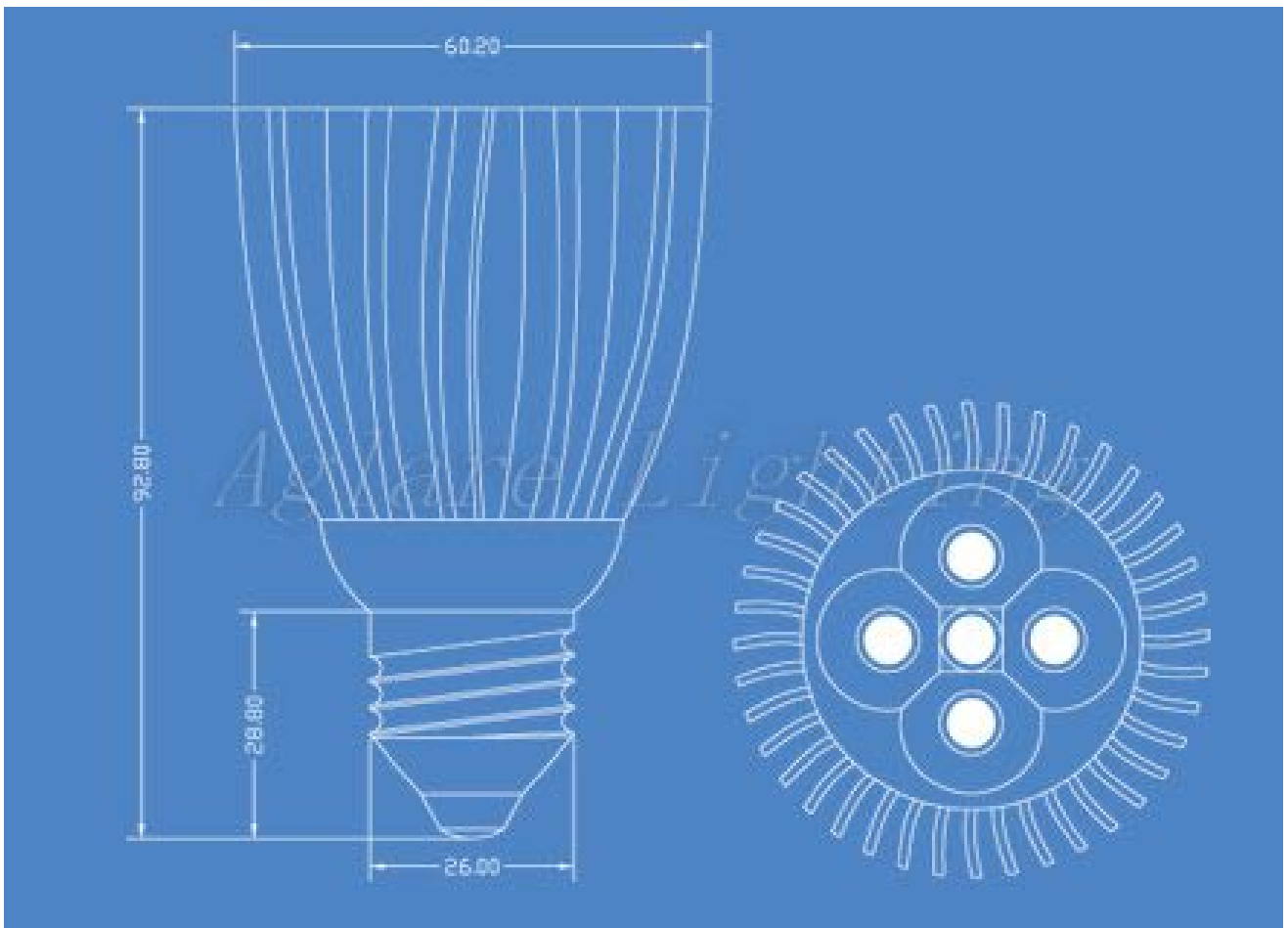

4.Absolute Maximum Rating at TA=25°C:



SHENZHEN AGLARE LIGHTING CO., LTD.

Tel: +86-755-88868631

FAX: +86-755-88863251

E-mail: Aglare@aglare.cn

Website: <http://www.aglare.cn>

Add: Factory A, Supply and Marketing Cooperative Park Guanlan Avenue, Guanlan Town Bao'an District, Shenzhen City, Guangdong, China

Part Number	Emitting Color	Input Voltage	Wattage	Waterpro of Degree	LED Quantity	Luminous Intensity(Lm)		Net Weight (g)
						MIN	MAX	
YJ-D60PAR20-5*1R	Red	AC90-24 0V	5W	/	5pcs	202	292	72g
YJ-D60PAR20-5*1G	Green			/		320	450	
YJ-D60PAR20-5*1B	Blue			/		55	70	
YJ-D60PAR20-5*1Y	Yellow			/		202	292	
YJ-D60PAR20-5*1W	Pure White			/		320	450	
YJ-D60PAR20-5*1WW	Warm White			/		260	360	

5. Characteristic:

Electro-Optical characteristics (White)						(Ta=25°C)	
Parameter	Test Condition	Symbol	Value			Unit	
			Min	Typ	Max		
Color temperature	If=320mA		5000		6500	K	
Forward Voltage	If=320mA		3.0		3.8	V	
Luminous intensity	If=320mA		320		450	Lm	
Useful life	If=320mA		30000		50000	H	

6.Lumen Decrease

Operating time (hours)	Lumen decrease [%]
1000	8
5000	15
10000	20

7. Package Information:



SHENZHEN AGLARE LIGHTING CO., LTD.

Tel: +86-755-88868631

FAX: +86-755-88863251

E-mail: Aglare@aglare.cn

Website: <http://www.aglare.cn>

Add: Factory A, Supply and Marketing Cooperative Park Guanlan Avenue, Guanlan Town Bao'an District, Shenzhen City, Guangdong, China

Net (g)	Gross (kg)	Box Size (cm)	Q'ty/BOX (PCS)	CTN1 Size (cm)	Q'ty/CTN1 (PCS)
72	8.2	6.5*6.5*9.0	1	33*33*36.5	100

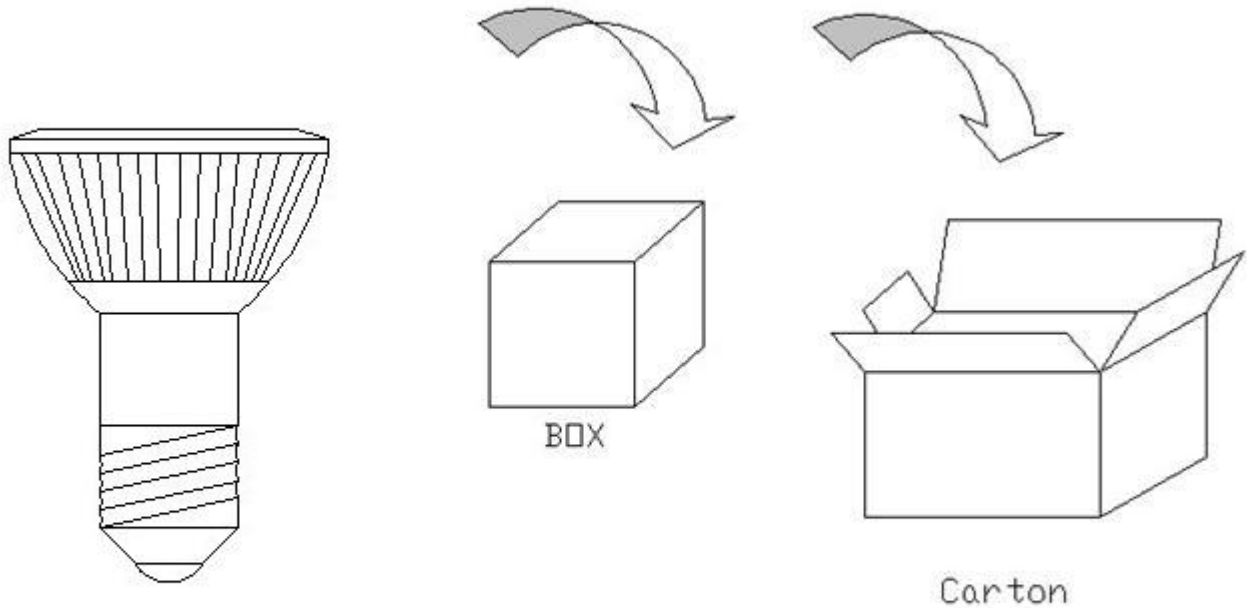

8. After-sales service:

All products are guaranteed to use in one year. Under the right and normal using condition, quality warranty is based on correct conservation, assemblage, and maintenance. As incorrect usage, and disobeying product operation, it's not guaranteed. To the problem within promised time, "Aglare" will solve it by repair, substitute accessories or replacement for your option. Upon exceeding the promised time, there will be material and maintenance fees to be paid by cu



SHENZHEN AGLARE LIGHTING CO., LTD.

Tel: +86-755-88868631

FAX: +86-755-88863251

E-mail: Aglare@aglare.cn

Website: <http://www.aglare.cn>

Add: Factory A, Supply and Marketing Cooperative Park Guanlan Avenue, Guanlan Town Bao'an District, Shenzhen City, Guangdong, China
